

Anatomy of a FLEXISORB

Pg. 1 2 3 4

Please note:
Dimensions are in "mm", millimetre - metric system. Some dimensions and gridlines on the blueprint may deviate from the original plan and to be used for guidance purposes only.

All information and illustrations are for guidance only and are subject to change without notification. DST do not accept liability for any errors or omissions herein.

Thermal break aluminium profile

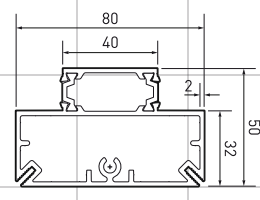
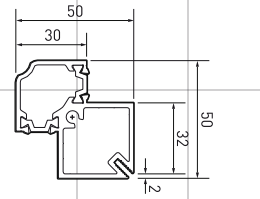

Material: EN AW 6060

Standard aluminium profile

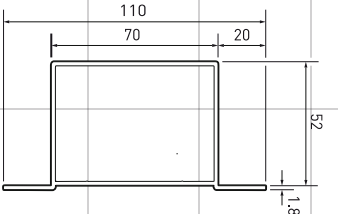
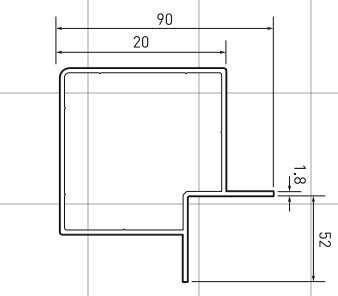

Material: EN AW 6060

-  Wet air outlet
-  Process air inlet
-  Dry air outlet

- Alternative bottom frames**
- Welded steel frame
 - Aluminium bottom frame

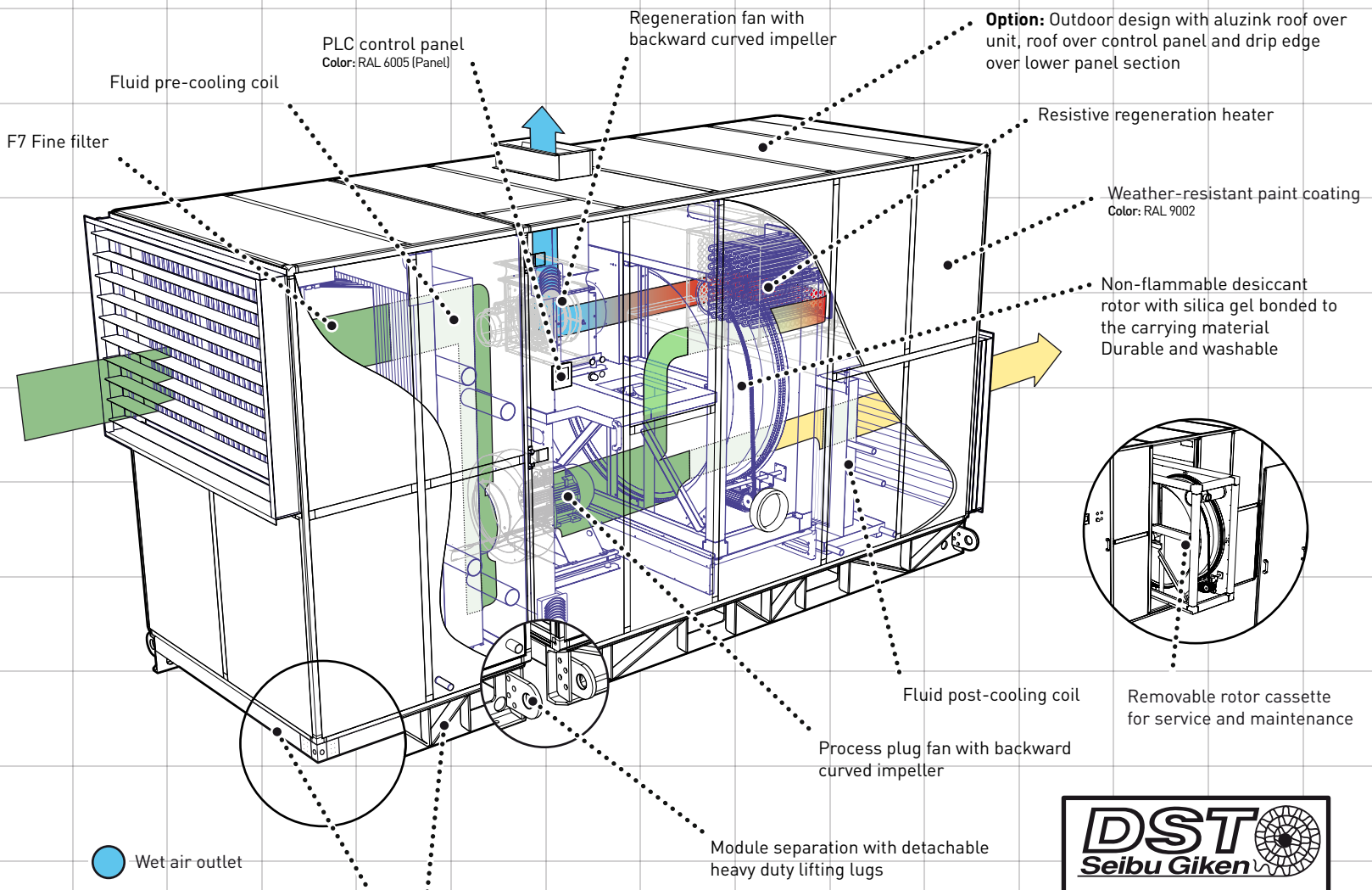

Option: Outdoor design with aluzink roof over unit, roof over control panel and drip edge over lower panel section

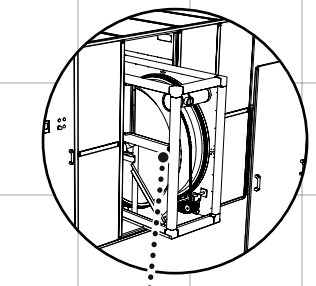

DST

Seibu Giken

Seibu Giken DST AB Tel: 46(0)8-4457720
 Avestagatan 33 http://www.dst-sg.com
 163 53 Spånga info@dst-sg.com
 Sweden

Revision no: RevF Version no: 2.0 Filename: Overview

Rotor cassette FLEXISORB

Pg. 



Seibu Giken DST AB
 Avestagatan 33
 163 53 Spånga
 Sweden

Tel: 46(0)8-4457720
<http://www.dst-sg.com>
 info@dst-sg.com

Revision no: RevC
 Version no: 1.3
 Filename: Rotor cassette

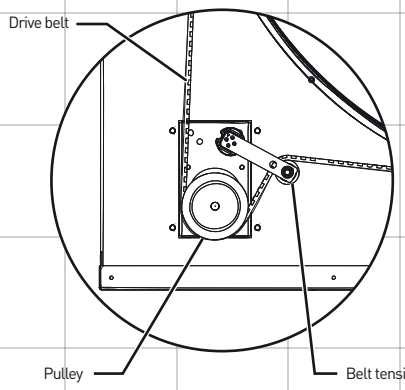
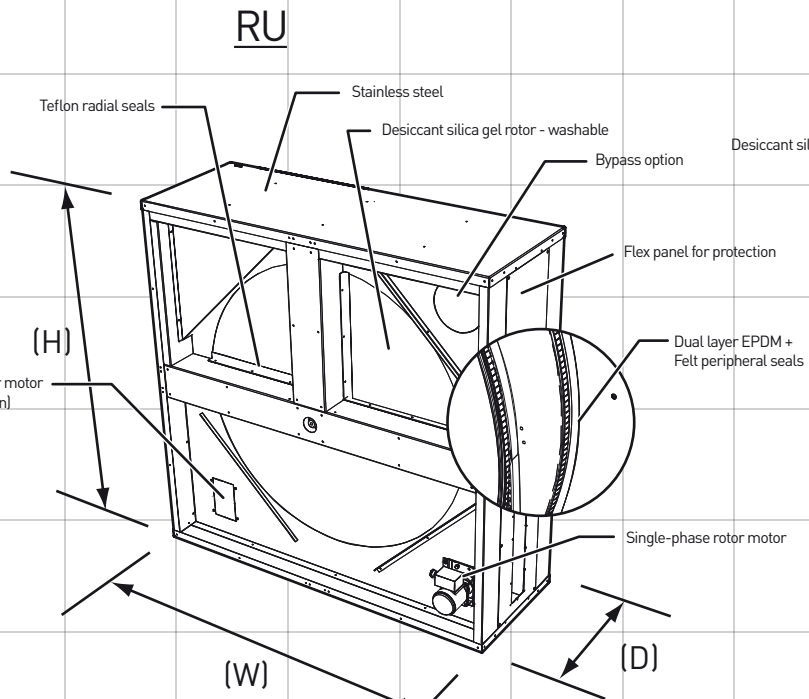

Model	Height [mm]	Width [mm]	Depth [mm]	Weight [kg]
RU-060	700	700	290	40
RU-061	700	700	340	45
RU-062	700	700	440	57
RU-082	920	920	440	85
RU-102	1220	1200	440	120

Self-adjusting mechanism uses the rotor motor weight to maintain correct chain tension

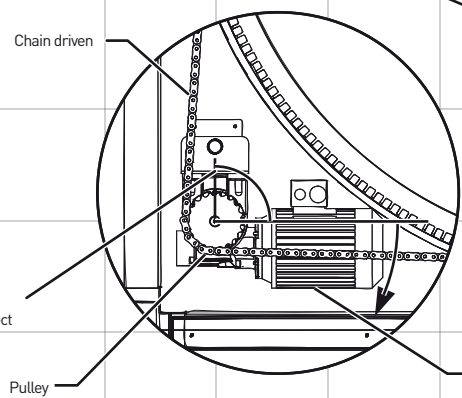
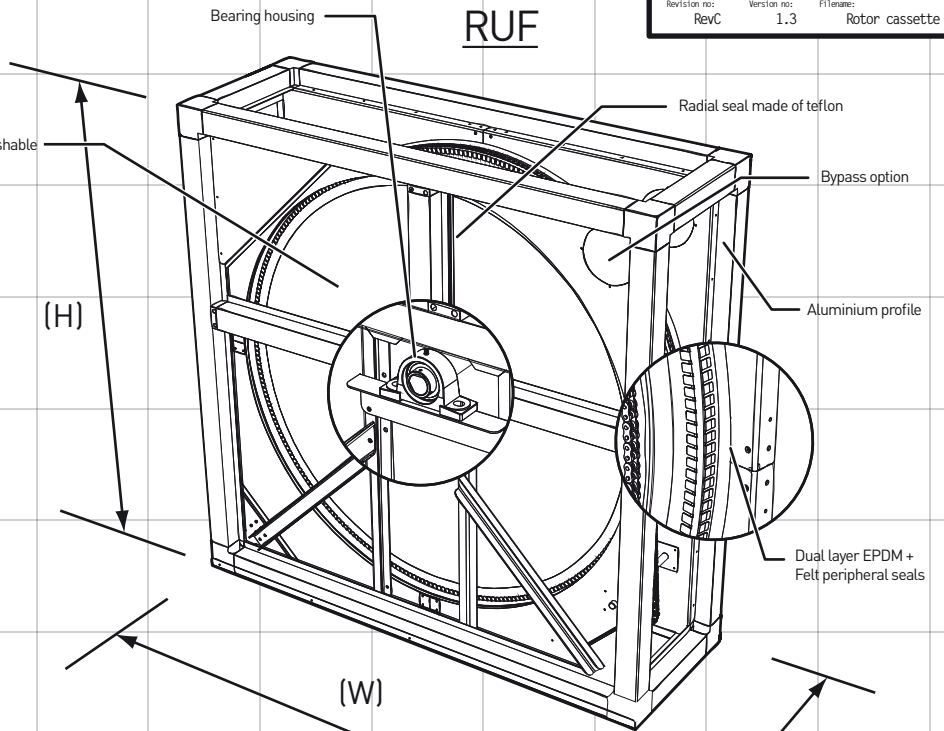

Model	Height [mm]	Width [mm]	Depth [mm]	Weight [kg]
RUF-122	1 500	1 500	500	250
RUF-152	1 805	1 805	500	320
RUF-172	2 010	2 010	500	360
RUF-192	2 220	2 220	500	450
RUF-222	2 470	2 470	500	650
RUF-242	2 700	2 700	500	760

Components FLEXISORB

Pg. 1 2 3 4

Programmable Logic Control

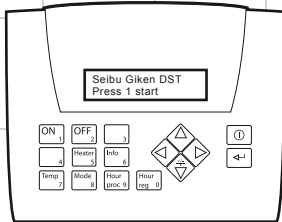

Type: C2, JZ10-11-UA24
The C2 offers a two 16-character text lines, LCD illuminated screen, with alphanumeric 16-key customisable keypad. A flexible 24K ladder code programming, on-board I/O configurations. The HMI application enables you to design up to 60 text screens, using up to 64 HMI variables for the display of time, date, and real-time system data.



Type: C4, V570
The touchscreen HMI enables the display of 'touchable' images and text according to real-time conditions—for on-line operation and diagnostics.

The C4 offers a rich range of embedded features such as multiple auto-tuned PID loops, internal 120K structured data table and loadcell support, Ethernet, GSM/SMS, MODBUS, networking, remote access and much more.

Regeneration fan

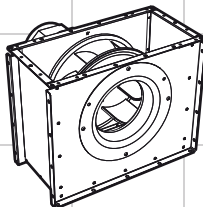

Material
ER-plug fan made as rugged bolted construction built with galvanised sheet steel. Inlet ring for optimum impeller inflow with measurement device for determining flow rate.

Process fan

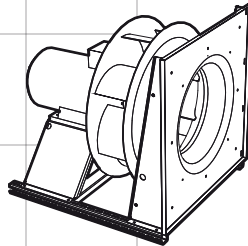

Blades: 7 backward curved blades made of steel sheet or hard resistant plastic
Max/Min permissible media temperature: 40°C / -20°C
Conforms to energy efficiency ErP 2009/640/EC directive
Motor class: IE2
IP class: IP55
VSD controlled using Vacon
Motor protection: PTC thermistor (PTC)
Manufacturer: Ziel-Abegg

Heat insulated panel

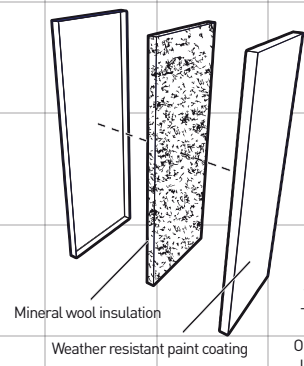

MINERAL WOOL SPECIFICATION
- 50 mm
- Rockwool
- 100kg/m³
- 0.045 W/m²K
- Flameproof class O (ISO1182)

PANEL SPECIFICATION
- Hot-zinc (UNI EN10142)
- 150 gr/mq
- Inside panel 1mm galvanized steel
- Outside panel 0.8mm galvanized steel

COATING SPECIFICATION
- Dual dry film layer
- 1st layer 5 µm
- 2st layer 25 µm
- RAL9002

OPTION
- INOX 304 or 316

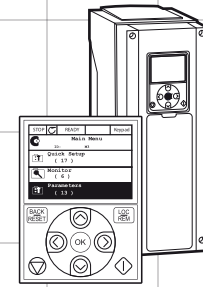

VSD

Type: AC drive
Input voltage 208...240, 380...500
Input frequency: 50...60 Hz -5...+10%
Standards: Compliance with global standards and approvals
E.g. EMC compliance, Safety: EN 61800-5-1 (2007)...
IP class: IP21 or IP54
Remote access: Built-in Modbus TCP and Modbus RTU
Feature: Real time clock with calendar based functions
Energy counter
Flying start
Motor Switch
3 Prohibit Frequency Ranges
Digital control panel
Safe torque off, Safe Stop
Manufacturer: Vacon

Fluid coils

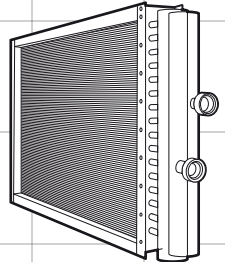

Material
The heat exchanger is designed using copper tubes and aluminium fins with a casing of hot-dip galvanised steel sheet and steel headers.
Conforms to SS-EN ISO 228-1, AMA-code QFC and Pressure Equipment Directive PED 97/23/EC.

Fluid
Max. Fluid velocity: 1.5 m/s in tubes.
Max. Air velocity: 5.0 m/s.

Steam coil

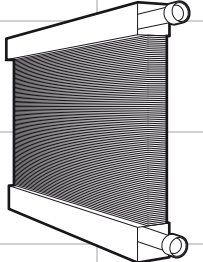

Steam
Max. Operating pressure: 10 bar(g)
Max. Operating temperature: 185°C

Header material	Max/Min temp	Max operating pressure
Fe	100/-20°C	1.6 Mpa
Cu (DN 80)	110/0°C	1.0 Mpa
Cu (DN 15-50)	110/0°C	1.6 Mpa

Gas heater

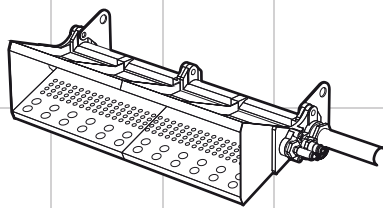

Material:
The burners consist of rust resistant cast iron bodies (which serve as the gas manifold) drilled to discharge the fuel between diverging stainless steel mixing plates. The main heater assembly houses the circulating air fan, the gas burner, the fuel gas line and all necessary safety and burner management system controls.

Burner type: Maxon LV-NP Direct fire heater
Material: Rust resistant cast iron bodies
Maximum effect: 300kW
Siemens electronic control box
Honeywell safety components

Electric heater

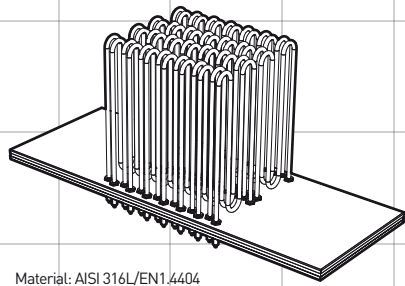

Material: AISI 316L/EN1.4404
Tube diameter: 8.5mm
Current: Max. 600V
Conforms to: EN60335-1 safety
Corrosion: Minimal due to low carbon
Max 700°C for use in corrosive environment
Connection: 2 nipples on each end secured using heat resistant bushing and nut
Bending radius: R12.5

Main filter

Type: Compact multi-pocket bag filter
Frame: Galvanised steel
Media: Glass fibre
EN779:2012 efficiency: F7
Recommended final pressure drop: 450 Pa
Temperature: 70°C

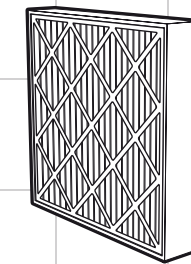
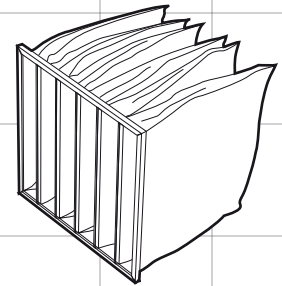

Pre-filter

Type: Disposable pleated panel filter
Frame: Moisture resistant cardboard
Media: Mixture of cotton & synthetic fibres
Gravimetric efficiency: 90%
EN779:2012 efficiency: G4
Recommended final pressure drop: 200 Pa

Thermal break FLEXISORB



Please note:
The thermal break system is optional

THERMAL BREAK SYSTEM T2 & B2 EN 1886

Thermal bridging

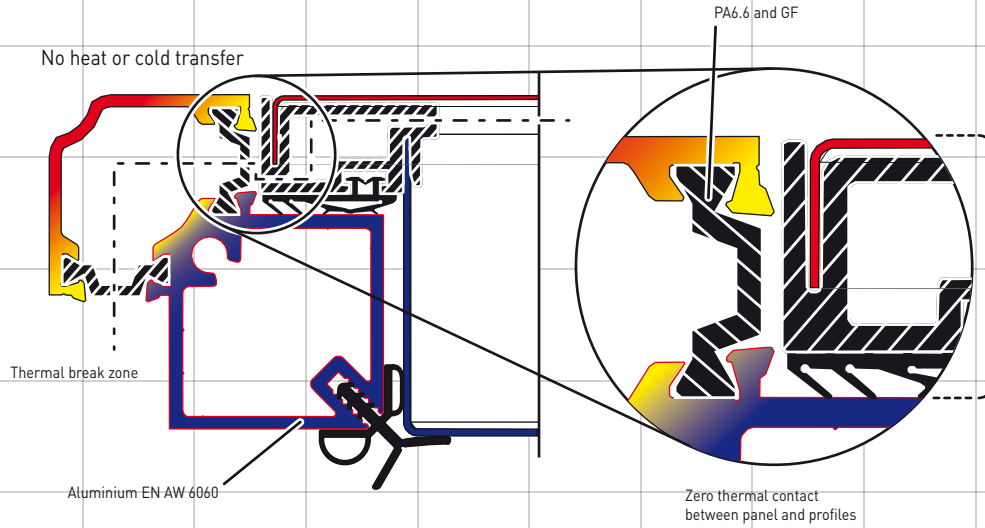

Panel design

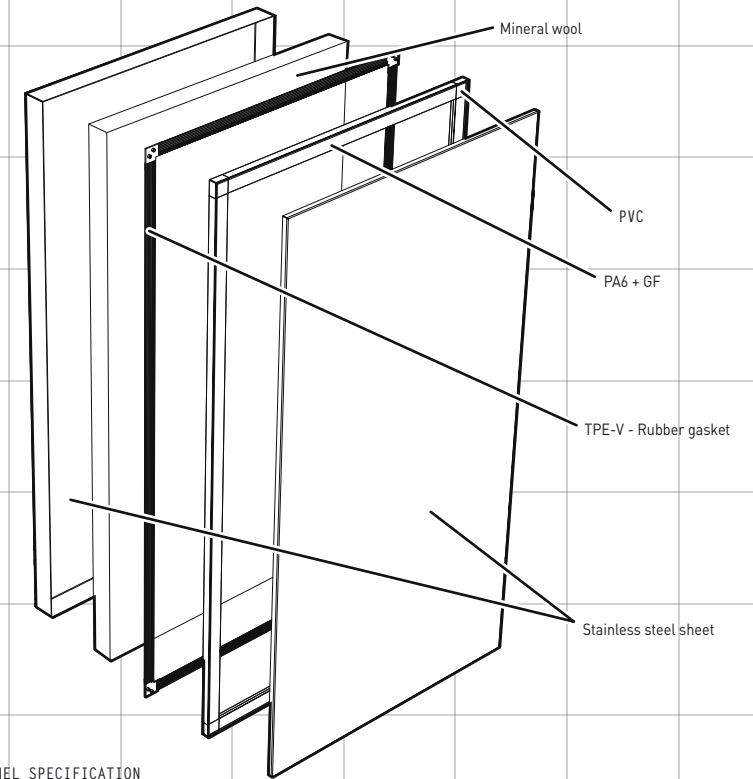

Air tight

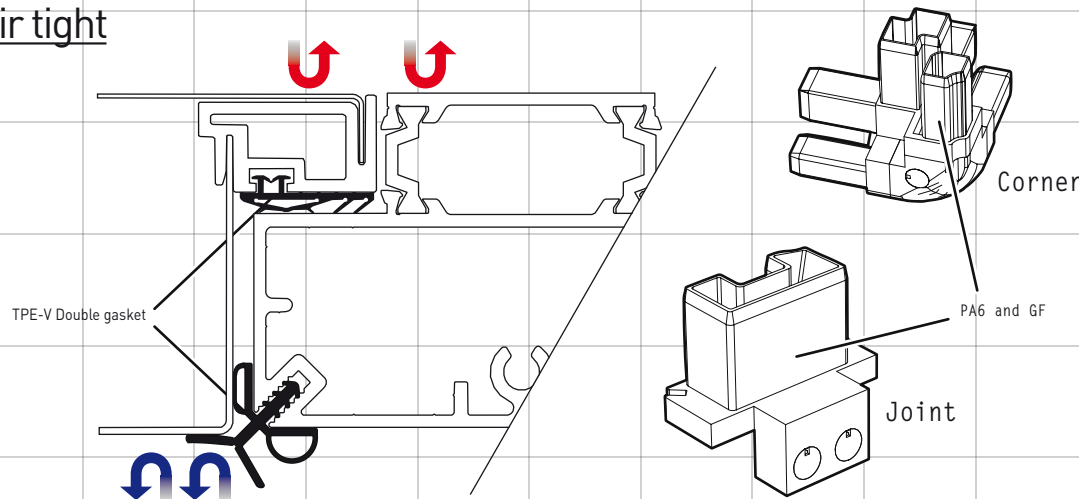

- PANEL SPECIFICATION**
- Hot-zinc (UNI EN10142)
 - 150 gr/mq
 - Inside panel 1mm galvanised steel
 - Outside panel 0.6mm galvanised steel

- COATING SPECIFICATION**
- Dual dry film layer
 - 1st layer 5 µm
 - 2st layer 25 µm

- MINERAL WOOL SPECIFICATION**
- 50 mm
 - Rockwool
 - 100kg/m³
 - 0.045 W/m*K
 - Flameproof class 0 (ISO1182)



Seibu Giken DST AB Tel:46(0)8-4457720
 Avestagatan 33 http://www.dst-sg.com
 163 53 Spånga info@dst-sg.com
 Sweden

Revision no: RevD Version no: 1.0 Filename: Profiles